



Programmable Touch Screen Control Panel (Wall-plate)

VLCT-4485IP



VER 1.0

User Manual

Thank you for purchasing this product

For optimum performance and safety, please read these instructions carefully before connecting, operating or adjusting this product. Please keep this manual for future reference.

Surge protection device recommended

This product contains sensitive electrical components that may be damaged by electrical spikes, surges, electric shock, lighting strikes, etc. Use of surge protection systems is highly recommended in order to protect and extend the life of your equipment.

Table of Contents

1. Introduction	1
2. Features	1
3. Package Contents	1
4. Specifications	2
5. Operation Controls and Functions	3
6. Product Dimensions	5
7. Mounting Instruction	5
8. Application Example	7

1. Introduction

The programmable touch screen control panel is designed to be utilized in the sectors of automated office system, multi-media room and smart home. With a programmable interactive user interface over configuration protocols, the integrated system provides intelligent networking service. The control panel wall-plate (standard 86 box design) is equipped with a capacitive touch screen with a resolution of 720*720, and it supports one RS-485 serial port. It is used in a diverse range of installations and applications across industries including multi-media conference rooms, multi-functional halls, training centers, show room, broadcasting studios and industrial automation.

2. Features

- ☆ ARM Cortex-A53 architecture 1.8Ghz main frequency
- ☆ Android 9.0 system, 8GB Emmc Flash, 2GB DDR4 RAM
- ☆ 720*720 (1:1) resolution, standard 86 box wall-plate design
- ☆ One machine with two modes, can be used as touch screen central control or user terminal
- ☆ Support one RS-485 communication serial port, which is capable of configuring 8 baud rates in the range of 2400-115200bps
- ☆ Support access to the host system management web page with a password
- ☆ Compliant with industry standard network communication protocols (TCP/IP, Http, UDP, Websocket)
- ☆ With 1 Gigabit network port, the highest rate up to 1G/bps
- ☆ Support POE function or independent DC 24V/1A power supply
- ☆ Interface and function configuration via central control software
- ☆ Support remote control, remote O&M, online upgrade
- ☆ Support factory reset

3. Package Contents

- ① 1 × Programmable Touch Screen Control Panel (Wall-plate)
- ② 1 × 3pin-3.81mm Phoenix Connectors (male)
- ③ 1 × 24V 1A Multinational Power Supply (2pin-3.81mm Phoenix Connector)
- ④ 1 × User Manual

4. Specifications

Technical	
CPU	ARM Cortex-A53 1.8GHz
Operation System	Android 9
RAM	2GB DDR4 RAM
Flash Memory	8GB EMMC Flash
Resolution	720*720
Touch Type	Capacitive Touch Screen
Connection	
RS-485	1 × 3-pin Phoenix Connectors, for RS-485 serial data communication
LAN/POE	1 standard 10M/100M/1000M Ethernet RJ45 interface, supporting POE function
POWER	1 × 2-pin Phoenix Connectors, for power supply
DEBUG	1 × Micro USB, system debugging port
Mechanical	
Housing	Front Panel — Touch Screen; Rear Case — Plastic
Color	Front Panel — Black; Rear Case — Apple Gray
Dimension	86 (W) × 38mm (D) × 86mm (H)
Weight	186g
Power Supply	24V DC/1A or POE
Power Consumption	5W
Operation Temperature	0°C ~ 40°C / 32°F ~ 104°F
Relative Humidity	10~90% RH (non-condensing)

5. Operation Controls and Functions

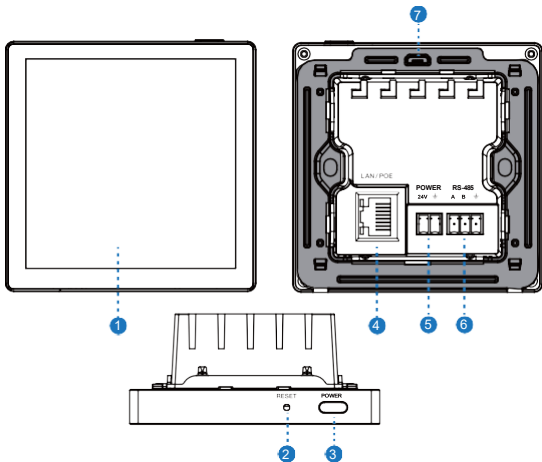

No.	Name	Function Description
1	Touch Screen	Capacitive touch screen. The user control interface can be configured through the IDE tool.
2	RESET button	<p>Reboot: After the device boots up, press and hold the RESET button for more than 1s less than 5s, then release it, the device will reboot. The device won't upload the user projects after rebooting.</p> <p>Reset: After the device boots up, press and hold the RESET button for more than 5s, then release it, the device will reset the user configuration information, the IP will be restored to DHCP state, the login password of the management page will be initialized to "admin", the device time will be initialized to automatic acquisition mode, but user projects won't be deleted by factory initialization.</p>

No.	Name	Function Description
3	POWER button	Used for screen off or wake-up.
4	LAN/POE port	<p>Standard 10M/100M/1000M Ethernet RJ45 port with default auto-negotiated speed for device connection, projects uploading & downloading, network communication and debugging.</p> <p>The control panel boots up with DHCP enabled by default. After powering on, when the control panel connects to a network where there is no router present to assign IP addresses, the control panel will take the pre-set IP address: 192.168.0.101. If there is a router present on the same network, the router will assign an IP address to the control panel in three minutes and the pre-set IP address will be invalid.</p> <p>Note: <i>When the control panel is DHCP enabled after power on, the router (if connected to the same network) will assign an IP address to the control panel. If network is disconnected at this time, the control panel won't be able to pre-set an IP address and its IP address would be 0.0.0.0. If a pre-set IP address is needed, you need to power off the control panel and then power it on again. If it is in static IP mode after power on, the control panel won't preset an IP address either. If there is no router present, you can connect your PC to the LAN port of the control panel and modify the PC's IP address in the network segment of 192.168.0.X, then the PC will pre-set an IP address to the control panel in three minutes for data communication.</i></p>
5	POWER port	The power input port (2-PIN phoenix connectors), used for connecting with external 24V DC power supply.
6	RS-485 port	<p>Programmable RS-485 serial port, which is a 3-pin phoenix connector (male), compliant with RS-485 communication protocol, and capable of configuring 8 baud rates in the range of 2400-115200bps.</p> <p>The pin-outs of the RS-485 ports are PIN1 for A, PIN2 for B, and PIN3 for GND.</p>
7	USB port	Micro USB port. The reserved port for system debugging.

6. Product Dimensions

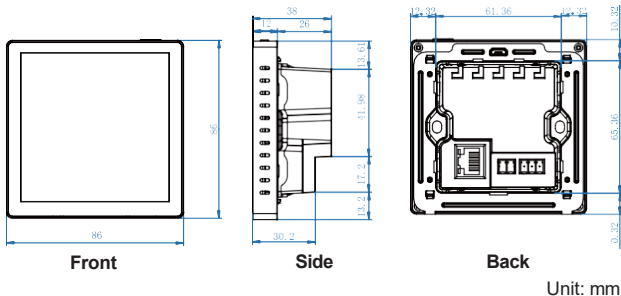

7. Mounting Instruction

This wall-plate can be mounted in a standard 86 wall box, the mounting steps are as follows.

Step 1: Embed the back part of the wall-plate into a 86 wall box, and fasten it with screws.

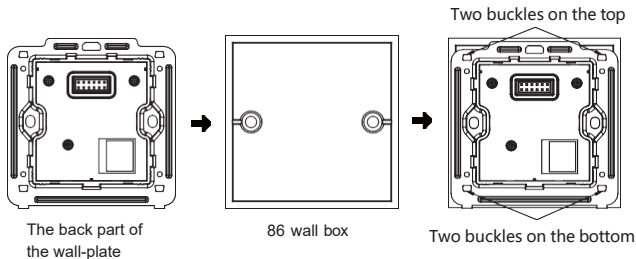

Step 2: Align the front part of the wall-plate with the socket at the rear of the wall-plate, then press the Force Point 1 and Force Point 2 (see the figure below) perpendicular to the wall at the same time, until the two buckles on the top are fully buckled.

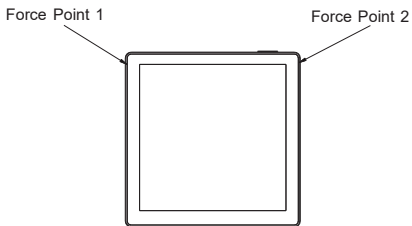

Step 3: Push the front part of the wall-plate up in the direction of the arrow as shown in the figure below, then press Force Point 3 and Force Point 4 perpendicular to the wall at the same time, until the two buckles on the bottom are fully buckled.

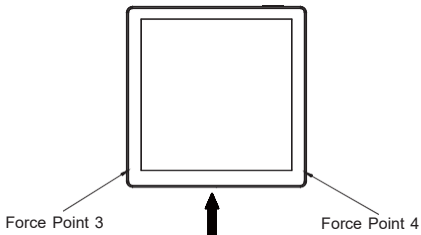

8. Application Example

